

Seat ventilation blower

DRF-29A306 EV-T



Size 105 x 105 x 20 mm

Motor Specification

Type of motor	-	DC Brushless
Weight	g	135
Size	mm	105 x 105
Thickness at housing scroll	mm	20
Motor output	W	3.6
Maximum current	A	0.8
Operating voltage range	V	9 to 16
Operating temperature	°C	-40 to 80
Storage temperature	°C	-40 to 85
Operating relative humidity	%	95
Maximum pressure	Pa	468
Maximum flow	CFM	25
Speed	RPM	5,760
Noise	dB(A)	55
Bearing type	-	Sleeve
IP rating	-	IP52
Housing material	-	Plastic
Impeller material	-	Plastic
Interface	-	Power, Ground, Speed control (PWM or Analog)

P-Q Performance Curve

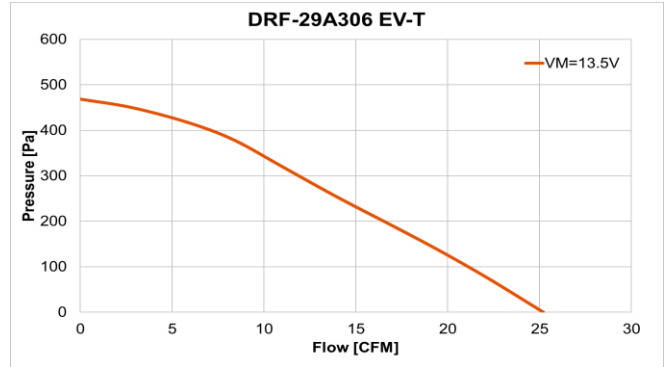

Noise Performance Curve

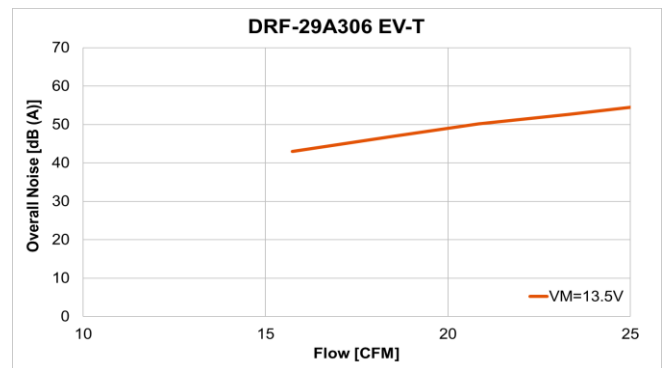

Dimension

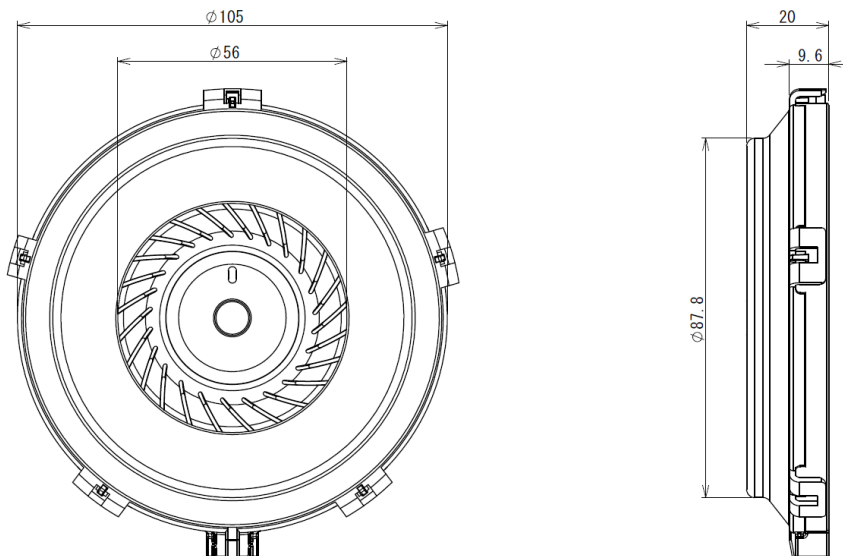

Japan (Headquarters)

Shinano Kenshi Co., Ltd.

1078, Kami-maruko, Ueda City, Nagano 386-0498
Japan
jp.aspina-group.com

USA

ASPINA Inc.

18952 MacArthur Boulevard, Suite 230, Irvine, California 92612
U.S.A.
us.aspina-group.com

Europe

ASPINA GmbH

Köln Str. 12, 65760 Eschborn
Germany
eu.aspina-group.com